

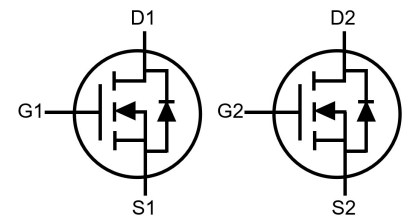
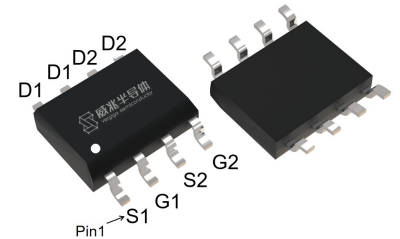
## Features

- Dual N-Channel, 5V Logic Level Control
- Enhancement mode
- Low on-resistance  $R_{DS(on)}$  @  $V_{GS}=4.5\text{ V}$
- VitoMOS<sup>®</sup> Technology
- Fast Switching and High efficiency
- Pb-free lead plating; RoHS compliant



Part ID	Package Type	Marking	Packing
VS5814DS	SOP8	5814DS	3000pcs/reel

$V_{DS}$	55	V
$R_{DS(on),TYP}@ V_{GS}=10\text{ V}$	16	m $\Omega$
$R_{DS(on),TYP}@ V_{GS}=4.5\text{ V}$	22	m $\Omega$
$I_D$	9	A

**SOP8**


## Maximum ratings, at $T_A=25\text{ }^\circ\text{C}$ , unless otherwise specified

Symbol	Parameter	Rating	Unit	
$V_{(BR)DSS}$	Drain-Source breakdown voltage	55	V	
$V_{GS}$	Gate-Source voltage	$\pm 20$	V	
$I_S$	Diode continuous forward current	$T_A=25\text{ }^\circ\text{C}$	1.7	A
$I_D$	Continuous drain current @ $V_{GS}=10\text{ V}$	$T_A=25\text{ }^\circ\text{C}$	9	A
		$T_A=100\text{ }^\circ\text{C}$	5.6	A
$I_{DM}$	Pulse drain current tested ①	$T_A=25\text{ }^\circ\text{C}$	36	A
EAS	Avalanche energy, single pulsed ②	31	mJ	
$P_D$	Maximum power dissipation	$T_A=25\text{ }^\circ\text{C}$	2	W
$T_{STG}, T_J$	Storage and junction temperature range	-55 to 150	$^\circ\text{C}$	

## Thermal Characteristics

Symbol	Parameter	Typical	Unit
$R_{\theta JL}$	Thermal Resistance, Junction-to-Lead	40	$^\circ\text{C/W}$
$R_{\theta JA}$	Thermal Resistance, Junction-to-Ambient	62.5	$^\circ\text{C/W}$

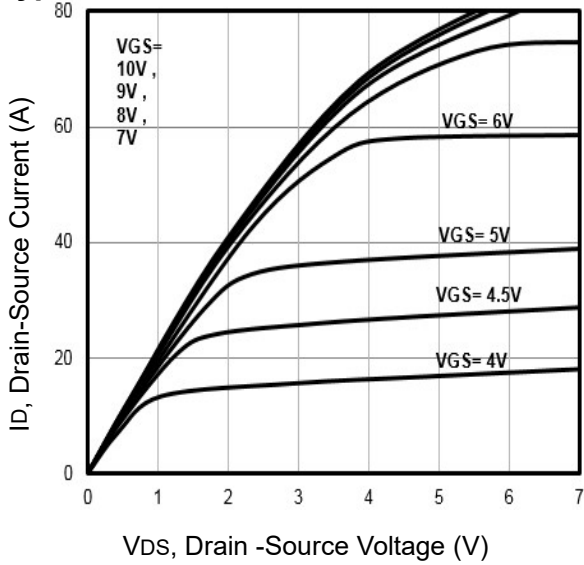
**Electrical Characteristics**

Symbol	Parameter	Condition	Min.	Typ.	Max.	Unit
<b>Static Electrical Characteristics @ T<sub>J</sub> = 25°C (unless otherwise stated)</b>						
V <sub>(BR)DSS</sub>	Drain-Source Breakdown Voltage	V <sub>GS</sub> =0V, I <sub>D</sub> =250μA	55	--	--	V
I <sub>DSS</sub>	Zero Gate Voltage Drain Current(T <sub>J</sub> =25°C)	V <sub>DS</sub> =50V, V <sub>GS</sub> =0V	--	--	1	μA
	Zero Gate Voltage Drain Current(T <sub>J</sub> =125°C)	V <sub>DS</sub> =50V, V <sub>GS</sub> =0V	--	--	100	μA
I <sub>GSS</sub>	Gate-Body Leakage Current	V <sub>GS</sub> =±20V, V <sub>DS</sub> =0V	--	--	±100	nA
V <sub>GS(TH)</sub>	Gate Threshold Voltage	V <sub>DS</sub> =V <sub>GS</sub> , I <sub>D</sub> =250μA	1.3	1.9	2.4	V
R <sub>DS(ON)</sub>	Drain-Source On-State Resistance ③	V <sub>GS</sub> =10V, I <sub>D</sub> =8A	--	16	21	mΩ
R <sub>DS(ON)</sub>	Drain-Source On-State Resistance ③	V <sub>GS</sub> =4.5V, I <sub>D</sub> =6A	--	22	29	mΩ
<b>Dynamic Electrical Characteristics @ T<sub>J</sub> = 25°C (unless otherwise stated)</b>						
C <sub>iss</sub>	Input Capacitance	V <sub>DS</sub> =25V, V <sub>GS</sub> =0V, f=1MHz	1000	1250	1500	pF
C <sub>oss</sub>	Output Capacitance		40	95	150	pF
C <sub>rss</sub>	Reverse Transfer Capacitance		30	60	90	pF
R <sub>g</sub>	Gate Resistance	f=1MHz	--	4.3	--	Ω
Q <sub>g</sub>	Total Gate Charge	V <sub>DS</sub> =25V, I <sub>D</sub> =8A, V <sub>GS</sub> =10V	--	22	--	nC
Q <sub>gs</sub>	Gate-Source Charge		--	5.2	--	nC
Q <sub>gd</sub>	Gate-Drain Charge		--	5	--	nC
<b>Switching Characteristics</b>						
t <sub>d(on)</sub>	Turn-on Delay Time	V <sub>DD</sub> =25V, I <sub>D</sub> =8A, R <sub>G</sub> =3Ω, V <sub>GS</sub> =10V	--	8	--	ns
t <sub>r</sub>	Turn-on Rise Time		--	4.4	--	ns
t <sub>d(off)</sub>	Turn-Off Delay Time		--	25	--	ns
t <sub>f</sub>	Turn-Off Fall Time		--	6	--	ns
<b>Source- Drain Diode Characteristics @ T<sub>J</sub> = 25°C (unless otherwise stated)</b>						
V <sub>SD</sub>	Forward on voltage	I <sub>SD</sub> =8A, V <sub>GS</sub> =0V	--	0.8	1.2	V
t <sub>rr</sub>	Reverse Recovery Time	T <sub>J</sub> =25°C, I <sub>sd</sub> =8A, V <sub>GS</sub> =0V	--	9	--	ns
Q <sub>rr</sub>	Reverse Recovery Charge	di/dt=500A/μs	--	8.5	--	nC

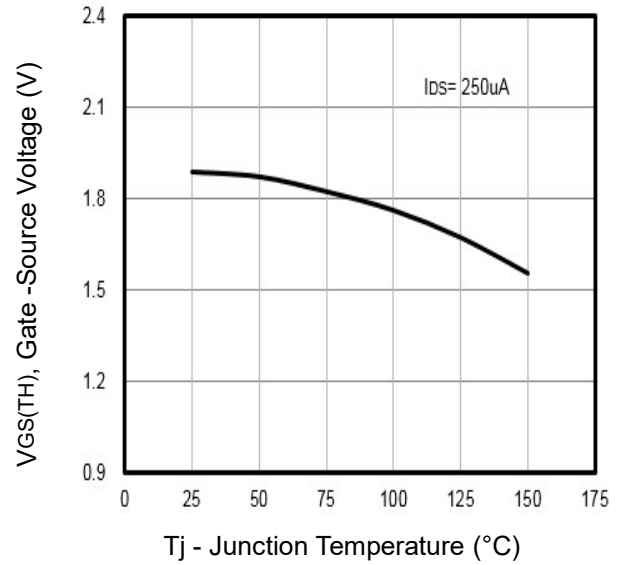
**NOTE:**

- ① Repetitive rating; pulse width limited by max. junction temperature.
- ② Limited by T<sub>Jmax</sub>, starting T<sub>J</sub> = 25°C, L = 0.5mH, R<sub>G</sub> = 25Ω, I<sub>AS</sub> = 9A, V<sub>GS</sub> = 10V. Part not recommended for use above this value
- ③ Pulse width ≤ 300μs; duty cycle ≤ 2%.

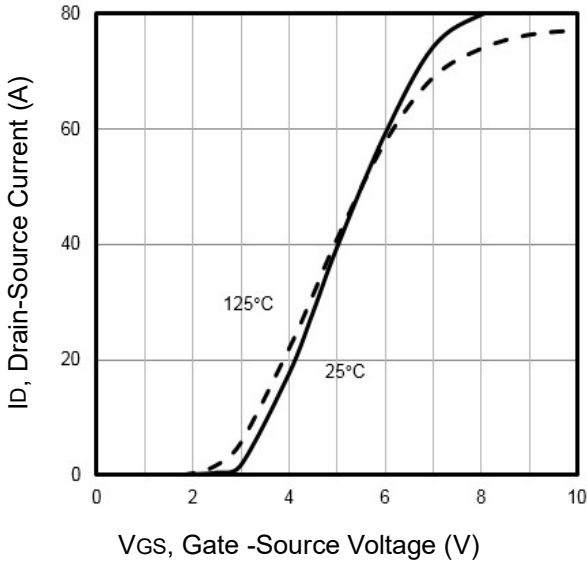
**Typical Characteristics**



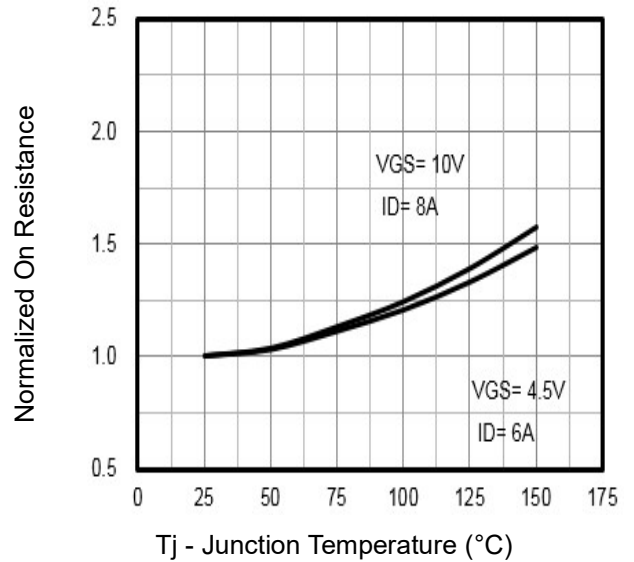
**Fig1.** Typical Output Characteristics



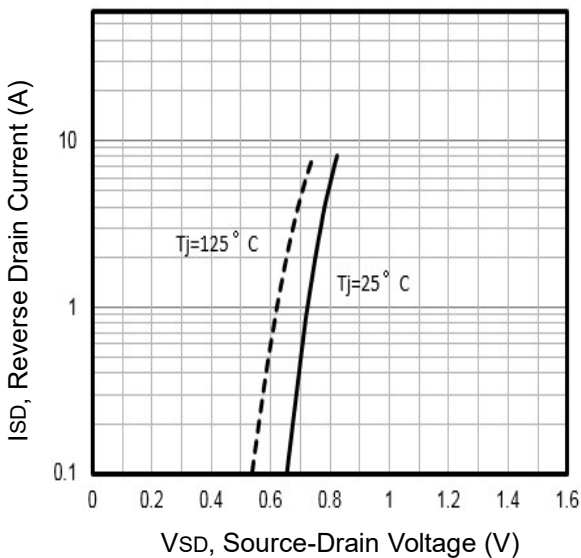
**Fig2.** Threshold Voltage Vs. Temperature



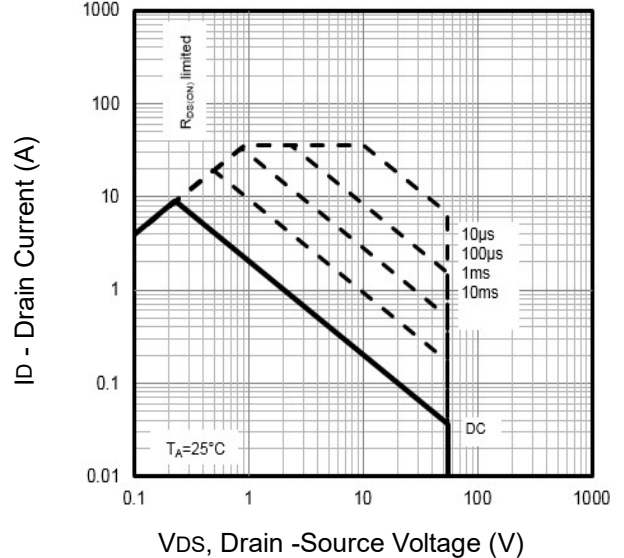
**Fig3.** Typical Transfer Characteristics



**Fig4.** Normalized On-Resistance Vs. Temperature

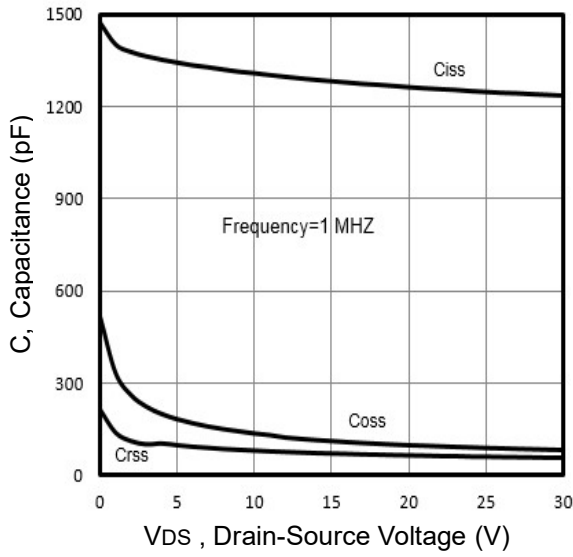


**Fig5.** Typical Source-Drain Diode Forward Voltage

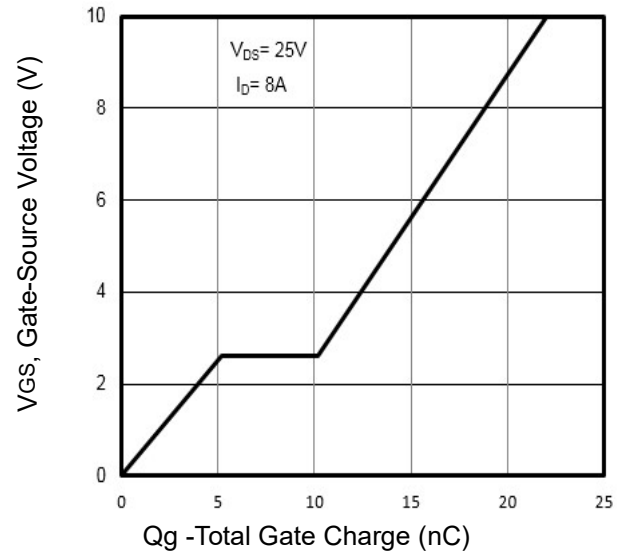


**Fig6.** Maximum Safe Operating Area

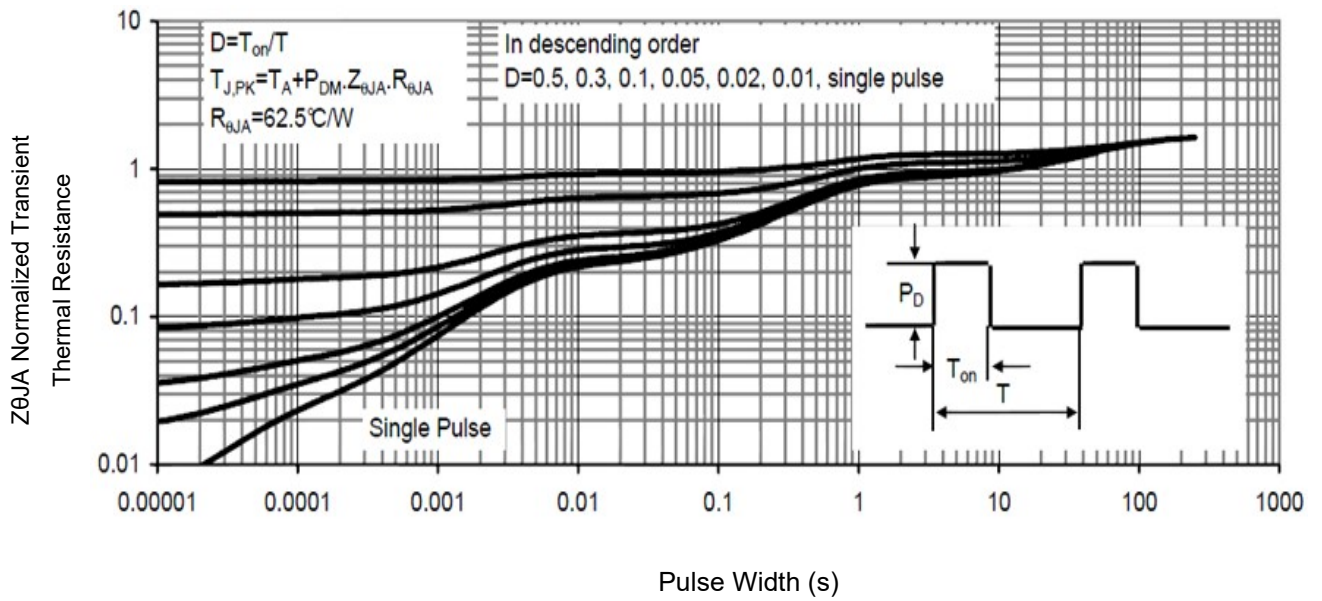
**Typical Characteristics**



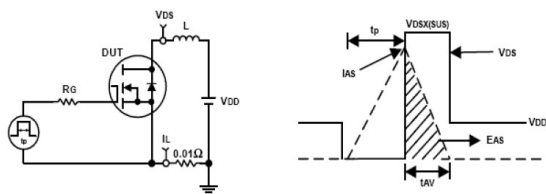
**Fig7.** Typical Capacitance Vs.Drain-Source Voltage



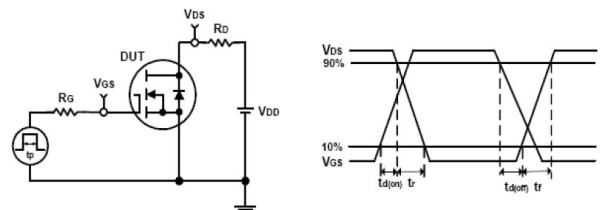
**Fig8.** Typical Gate Charge Vs.Gate-Source Voltage



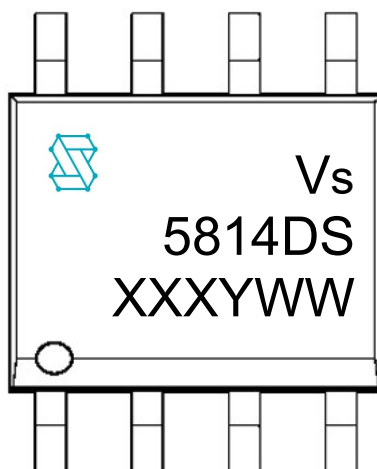
**Fig9.** Normalized Maximum Transient Thermal Impedance



**Fig10.** Unclamped Inductive Test Circuit and waveforms



**Fig11.** Switching Time Test Circuit and waveforms

**Marking Information**


1<sup>st</sup> line: Vergiga Code (Vs), Vergiga Logo

2<sup>nd</sup> line: Part Number (5814DS)

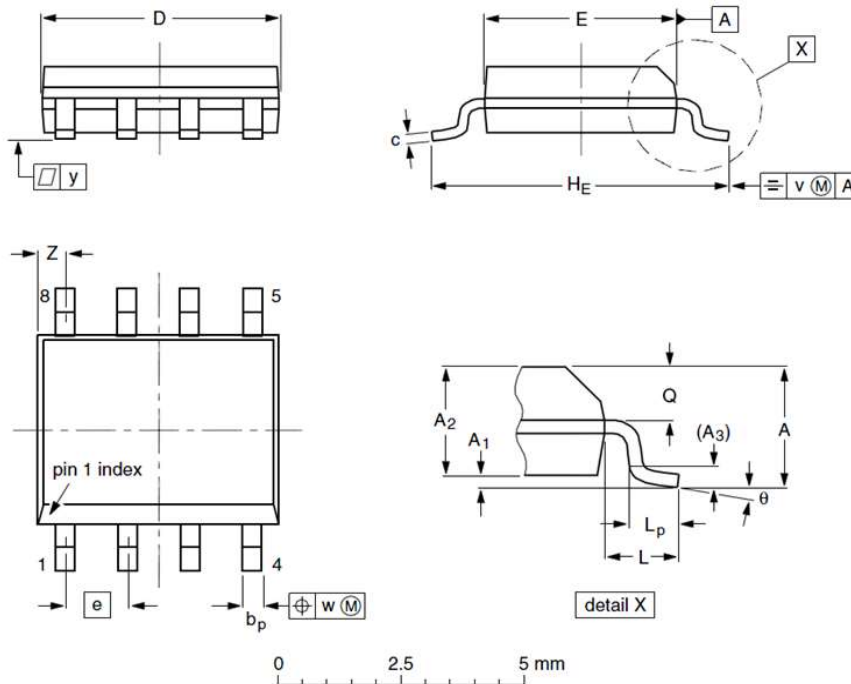
3<sup>rd</sup> line: Date code (XXXYWW)

XXX: Wafer Lot Number Code , code changed with Lot Number

Y: Year Code , refer to table below

WW: Week Code (01 to 53)

Code	C	D	E	F	G	H	J	K	L	M	N	P	Q	R	S	T
Year	2015	2016	2017	2018	2019	2020	2021	2022	2023	2024	2025	2026	2027	2028	2029	2030

**SOP8 Package Outline Data**


Label	Dimensions (unit: mm)		
	Min	Typ	Max
A	--	--	1.75
A <sub>1</sub>	0.10	0.18	0.25
A <sub>2</sub>	1.25	1.35	1.50
A <sub>3</sub>	--	0.25	--
b <sub>p</sub>	0.36	0.42	0.51
c	0.19	0.22	0.25
D	4.80	4.92	5.00
E	3.80	3.90	4.00
e	--	1.27	--
H <sub>E</sub>	5.80	6.00	6.20
L	--	1.05	--
L <sub>p</sub>	0.40	0.68	1.00
Q	0.60	0.65	0.725
v	--	0.25	--
w	--	0.25	--
y	--	0.10	--
Z	0.30	0.50	0.70
θ	0°		8°

**Notes:**

1. Follow JEDEC MS-012.
2. Dimension "D" does NOT include mold flash, protrusions or gate burrs. Mold flash, protrusions or gate burrs shall not exceed 0.15mm per side.
3. Dimension "E" does NOT include interlead flash or protrusion. Interlead flash or protrusion shall not exceed 0.25mm per side.
4. Dimension "b<sub>p</sub>" does NOT include dambar protrusion. Allowable dambar protrusion shall be 0.1mm total in excess of "b<sub>p</sub>" dimension at maximum material condition. The dambar cannot be located on the lower radius of the foot.

**Customer Service**
**Sales and Service:**
[sales@vgsemi.com](mailto:sales@vgsemi.com)
**Vergiga Semiconductor CO., LTD**
**TEL:** (86-755) -26902410

**FAX:** (86-755) -26907027

**WEB:** [www.vgsemi.com](http://www.vgsemi.com)